

REVISION

A	JB	J HENRY
6/16/2009	ECN-111954	RELEASE FOR PRODUCTION
B	MM	M BOONE
9/2/2009	ECN-116250	MULTIPLE VIEWS: CHG FROM 13 POSITIONS TO 10 POSITIONS, CHG DIMENSION FROM 17.91 TO 15.50, CHG DIMENSION FROM 14.73 TO 12.32, CHG DIMENSION FROM 9.60 TO 7.20, CHG DIMENSION FROM 16.21 TO 13.80, CHG DIMENSION FROM 13.53 TO 11.14, BOM: CHG QTY ITEM 2 FROM 26 TO 20
C	LF	M BOONE
10/15/2009	ECN-118447	BOM: CHG ITEM 1 FROM ERF8-013-05.0-DV-L TO ERF8-010-05.0-DV-L AND FROM ITEM 5 CT-ERF8027MS TO CT-ERF8038MS
D	JB	Z Paden
3/2/2010	ECN-126257	SHT 2, RECOMMENDED PCB LAYOUT, DEL 5.30 (TYP), ADD 1.80 REF, CHG 5.61 TO 5.60, CHG Ø0.8340.02 TO Ø0.8340.05, ADD NOTE TO BE SOLDERED USING PASTE-IN-HOLE TECHNOLOGY, RECOMMENDED STENCIL LAYOUT: CHG 16.20 TO 13.80, CHG Ø1.58(2 PLCS) TO Ø2.24(2 PLCS)

NOTES:

1. STANDARD PART SET UP AS ASP.
2. Ⓢ REPRESENTS A CRITICAL DIMENSION.
3. MAXIMUM BURR ALLOWANCE: .038 [.0015].
4. MINIMUM PUSHOUT FORCE: 2.22N [.5LB].
5. PARTS TO BE PACKAGED IN TAPE & REEL.

DESIGNED & DIMENSIONED IN MILLIMETERS [INCHES]

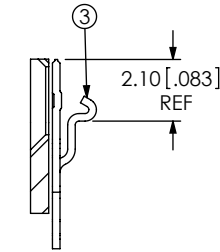
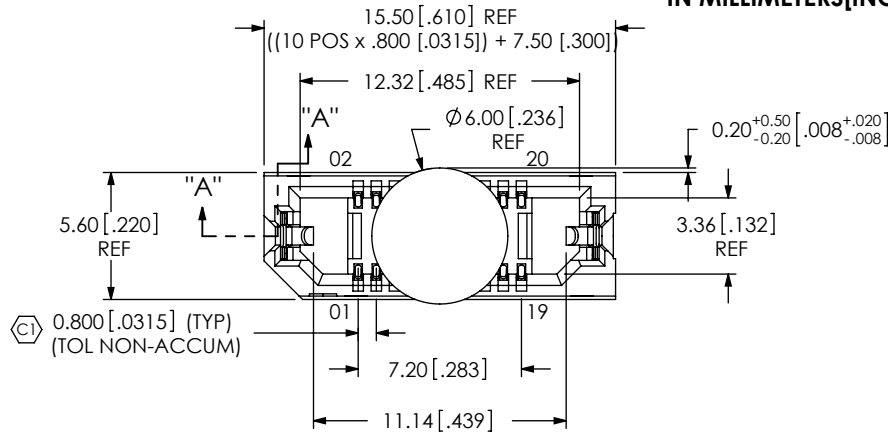

SECTION "A"- "A" SCALE 4 : 1

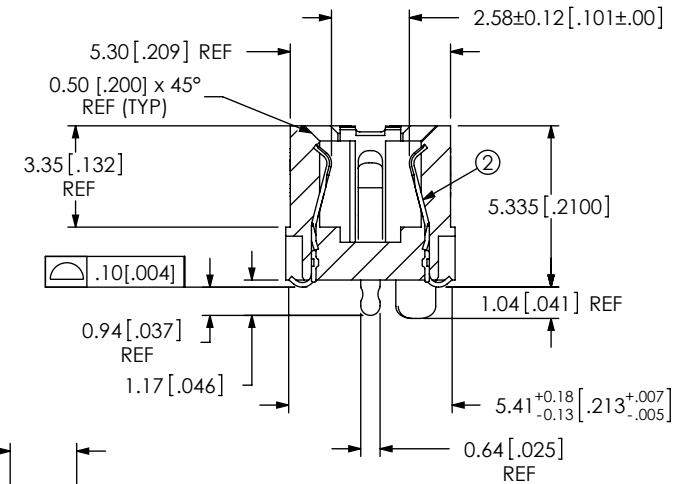
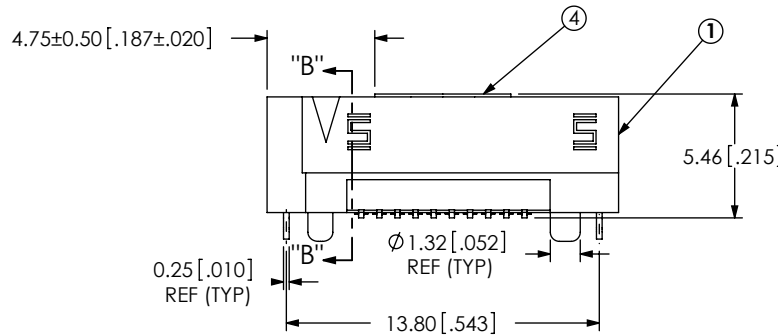

SECTION "B"- "B" SCALE 4 : 1

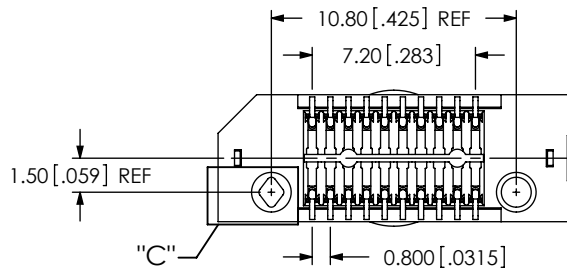

DETAIL "C" SCALE 8 : 1

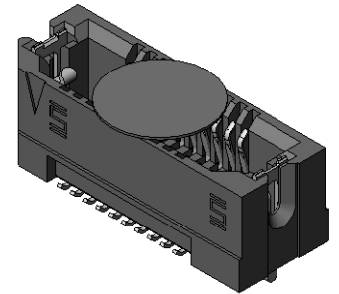

<input type="checkbox"/>	ACCEPTANCE OF DRAWING
<input type="checkbox"/>	ACCEPTED WITH DEVIATIONS LISTED
DATE:	CUSTOMER SIGNATURE
COMPANY:	PRINTED NAME
PHONE No:	PHONE No:
FAX No:	FAX No:

ITEM NO.	PART NUMBER	QUANTITY	MATERIAL
1	ERF8-010-05.0-DV-L	1.0000	VECTRA E130i, COLOR: BLACK Ⓢ
2	C-211-05.0-S	20.000	BeCu, 390 HT
3	WT-30-01-F	2.0000	BeCu, #25, 1/2 HT
4	K-500-300	1.0000	POLYIMIDE FILM
5	CT-ERF8038MS	1.0000	CONDUCTIVE POLYMER Ⓢ

UNLESS OTHERWISE SPECIFIED, DIMENSIONS ARE IN MILLIMETERS. TOLERANCES ARE:
 DECIMALS ANGLES
 .X: ±.3[.01] 2°
 .XX: ±.13[.005]
 .XXX: ±.051[.0020]

PROPRIETARY NOTE
 THIS DOCUMENT CONTAINS INFORMATION CONFIDENTIAL AND PROPRIETARY TO SAMTEC, INC. AND SHALL NOT BE REPRODUCED OR TRANSFERRED TO OTHER DOCUMENTS OR DISCLOSED TO OTHERS OR USED FOR ANY PURPOSE OTHER THAN THAT WHICH IT WAS OBTAINED WITHOUT THE EXPRESSED WRITTEN CONSENT OF SAMTEC, INC.

samtec
 520 PARK EAST BLVD, NEW ALBANY, IN 47150
 PHONE: 812-944-6733 FAX: 812-948-5047
 e-Mail: info@SAMTEC.com code 53322

DO NOT SCALE DRAWING SHEET SCALE: 1:0.3333
 PLATING:
 CONTACT AREA: .000030 MIN GOLD OVER .000050 MIN NICKEL
 REMAINDER: .000200 REF TIN OVER .000050 MIN NICKEL
 LATCHES: .000003 MIN GOLD OVER .000050 MIN NICKEL

DESCRIPTION: ERF8 ASSEMBLY
 DWG. NO. ASP-148421-01
 BY: J. BROWNING 06/16/2009 SHEET 1 OF 2

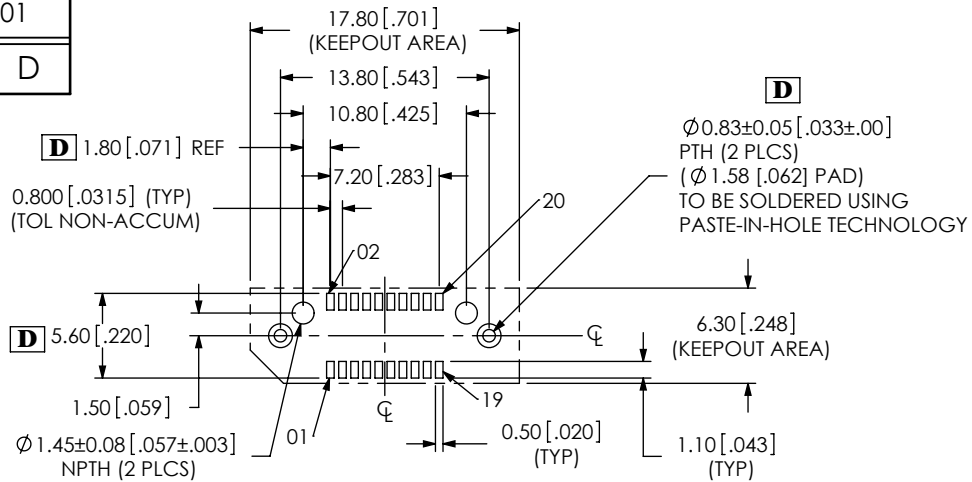

RECOMMENDED PCB LAYOUT

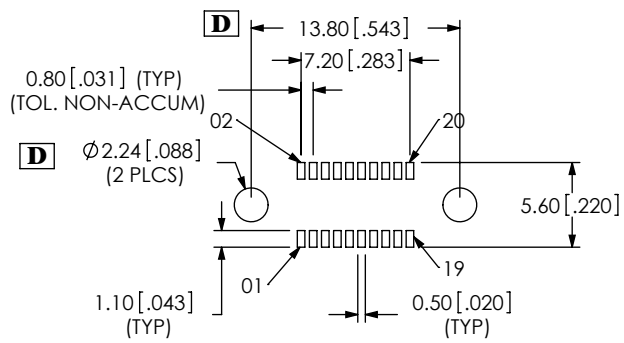

RECOMMENDED STENCIL LAYOUT

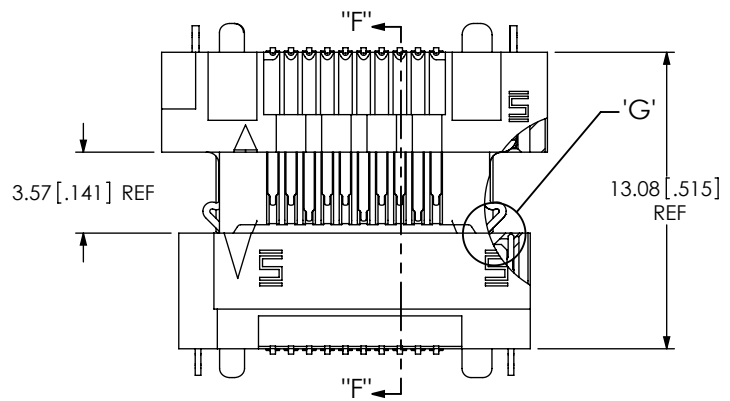

LATCH ENGAGING VIEW

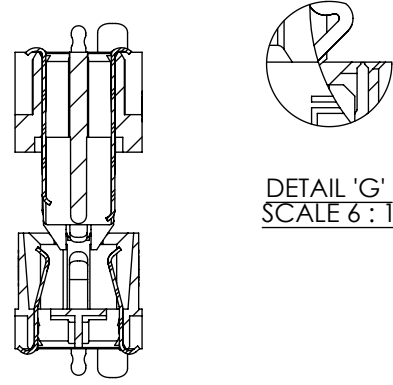

SECTION "F"-"F"



DETAIL 'G'
SCALE 6 : 1

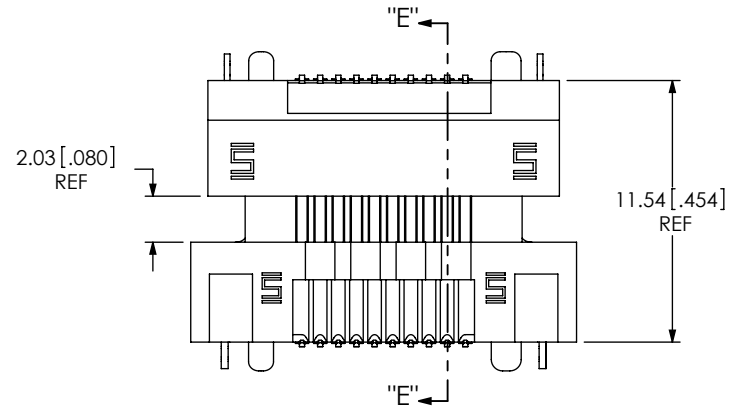

PIN ENGAGING VIEW

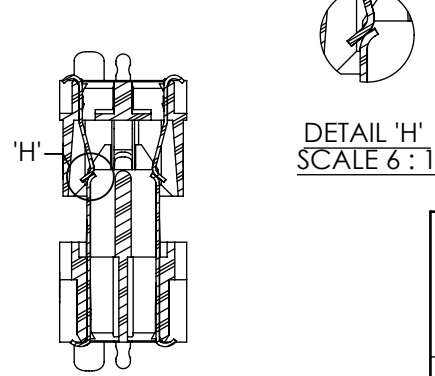

SECTION "E"-"E"



DETAIL 'H'
SCALE 6 : 1

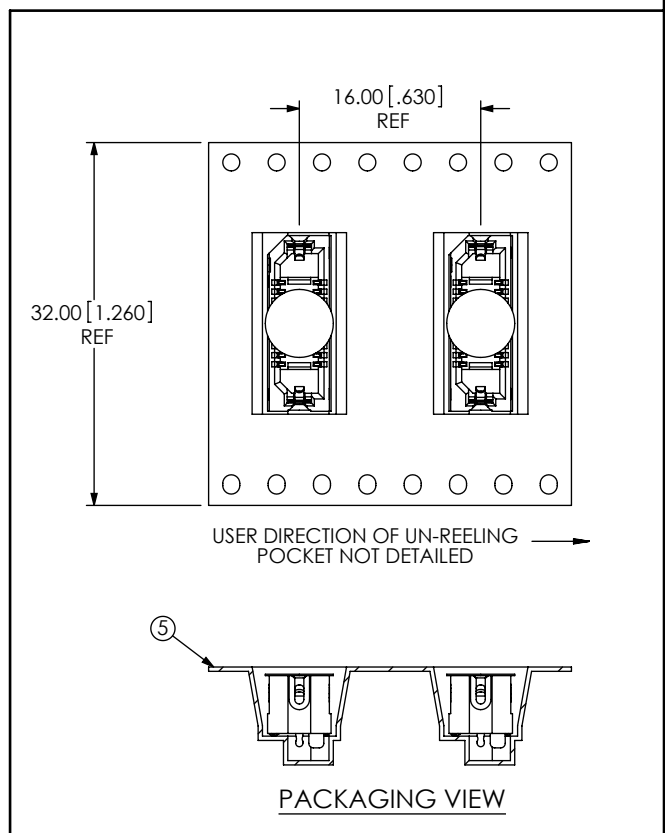

PACKAGING VIEW

PROPRIETARY NOTE

THIS DOCUMENT CONTAINS INFORMATION CONFIDENTIAL AND PROPRIETARY TO SAMTEC, INC. AND SHALL NOT BE REPRODUCED OR TRANSFERRED TO OTHER DOCUMENTS OR DISCLOSED TO OTHERS OR USED FOR ANY PURPOSE OTHER THAN THAT WHICH IT WAS OBTAINED WITHOUT THE EXPRESSED WRITTEN CONSENT OF SAMTEC, INC.



520 PARK EAST BLVD., NEW ALBANY, IN 47150
PHONE: 812-944-6733 FAX: 812-948-5047
e-Mail: info@SAMTEC.com code 53322

SHEET SCALE: 3:1

DESCRIPTION:

ERF8 ASSEMBLY

DWG. NO.

ASP-148421-01

BY: J. BROWNING 06/16/2009 SHEET 2 OF 2